

FQ-LED LED Ring illuminator

Features

- LED chips arrayed in double ring configuration to optimize cost and uniformity
- 2 LED cover options included. Diffuser and translucent (LED reflection suppressed) types.
- Compact design. Dimmer and power switch integrated in lighting module.
- Compatible with most microscope brands

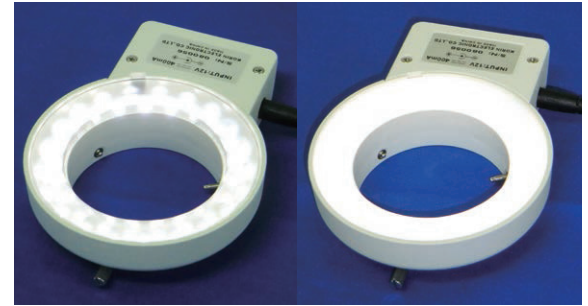

Diffuser cover

Translucent cover

Outline Drawing

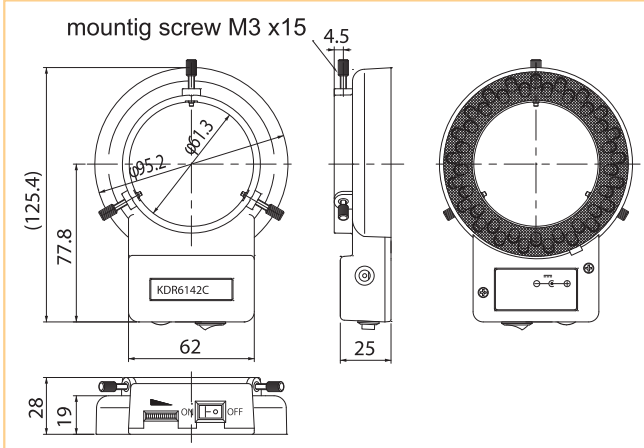

Specifications

Model	FQ-LED
Output voltage	DC12V
Power consumption	4W
AC adapter	Power supply: AC 100-240V 50/60Hz Output voltage: DC12V 0.5A
LED color	White
LED life span	20,000 (H)
Applicable height range	60mm to 150mm
Ring inner diameter	Max Φ 61
Suitable operation temp.	0 °C to + 40 °C
Weight	100g (AC adapter not included)

*Life span dependent on operating temperature

Dimmer integrated in lighting module



Luminous Spectrum

