

MT-40 Series Biological Microscope Manual

This manual expatiates the using method, troubleshooting and maintenance about MT-40 series biological microscope. Please study this manual thoroughly before operating, and keep it with the instrument. The manufacturer reserves the rights to the modifications by technology development. On the basis of operation ensured, technical specifications may be subject to changes without notice.

Before Use

1. Components.....	1
2. Assembling	3
2-1 <i>Assembling Scheme</i>	3
2-2 <i>Assembling Steps</i>	4
3. Operation	6
3-1 <i>Set Illumination</i>	6
3-2 <i>Place the Specimen Slide</i>	6
3-3 <i>Adjust the Focus</i>	7
3-4 <i>Adjust the Focusing Tension.....</i>	7
3-5 <i>Adjust the Interpupillary Distance</i>	7
3-6 <i>Adjust the Field Diaphragm (Iris Diaphragm Koehler Illuminator Condenser Optional).....</i>	8
3-7 <i>Adjust the Aperture Diaphragm</i>	8
3-8 <i>Use the Oil Objective (100X)</i>	9
3-9 <i>Use the Filter.....</i>	9
3-10 <i>Replace the Fuse</i>	10
4. Technical Specifications.....	11
4-1 <i>MT-40 Series Biological Microscope Technical Parameters.....</i>	11
4-2 <i>Parameters of objective.....</i>	11
5. Troubleshooting.....	12

1. Operation Notice

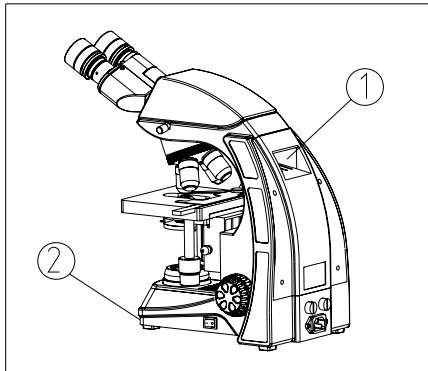

Fig. 1

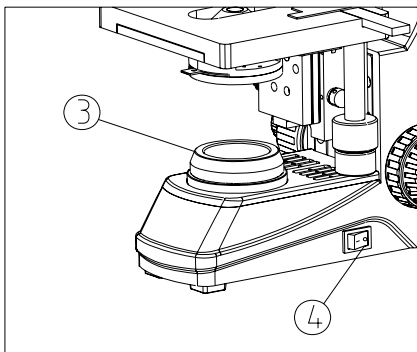

Fig. 2

1. As the microscope is a high precision instrument, always operate it with care, and avoid physical shake during the operation.
2. Do not expose the microscope in the sun directly, either not in the high temperature, damp, dust or acute shake. Make sure the worktable is flat and horizontal.
3. When moving the microscope, use both hands to hold its back hand-clasp ① and the front base ②, and lay it down carefully (see Fig. 1).
★ It will damage the microscope by holding the stage, focusing knob or head when moving.
4. When working, the surface of condenser will be very hot. Make sure there is enough room for the heat dissipating around the condenser ③ (see Fig. 2).
5. Connect the microscope to the ground to avoid lightning strike.
6. For safety, make sure the power switch ④ is at "0" (off) and power it off before replacing the bulb or fuse, and wait until the lamp cools down (see Fig. 2).
★ Bulb selected only: Single 3W LED light.
7. Wide voltage range is supported as 100~240V. Additional transformer is not necessary. Make sure the voltage is in this range.
8. Use the special wire supplied by our company.

2. Maintenance

1. Wipe the lens gently with a soft tissue. Carefully wipe off the oil marks and fingerprints on the lens surfaces with a tissue moistened with a small amount of 3:7 mixture of alcohol and ether or dimethylbenzene.

★ **As the alcohol and ether is flammable, don't place these chemical near to fire or fire source. For example, when turning on or turning off the electrical device, please use these chemical in a ventilated place.**

2. Don't use organic solution to wipe the surfaces of the other components. Please use the neutral detergent if necessary.

3. If the microscope is damped by liquid when using, please power it off immediately and wipe it dry.

4. Never disassemble the microscope, otherwise the performance will be affected or the instrument will be damaged.

5. After using, cover the microscope with a dust cover.

3. Safety Sign

Sign	Signification
	Study the instructions before use. Unsuitable operation would lead to person hurt or instrument faulty.
	Main switch ON
○	Main switch OFF

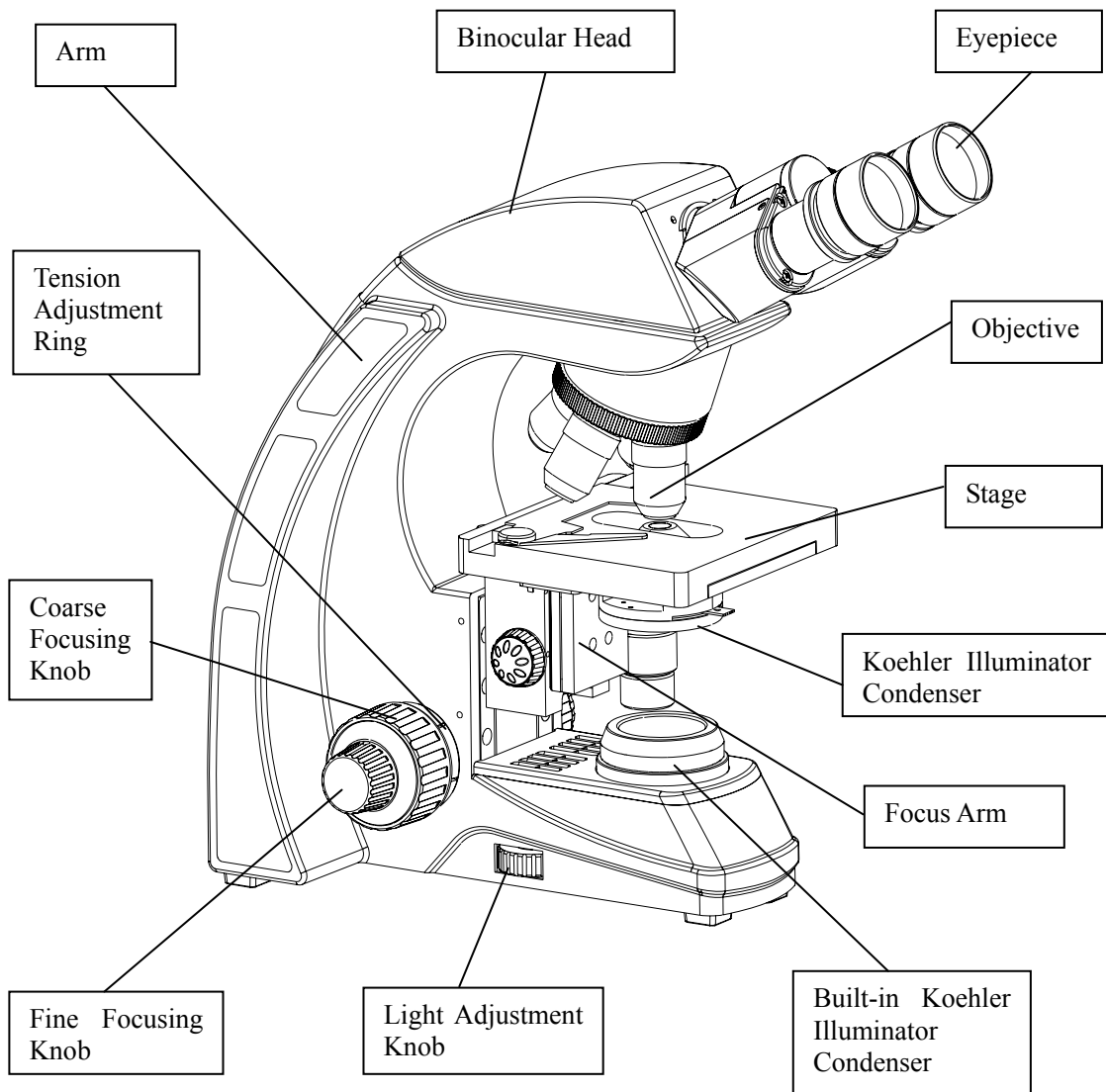

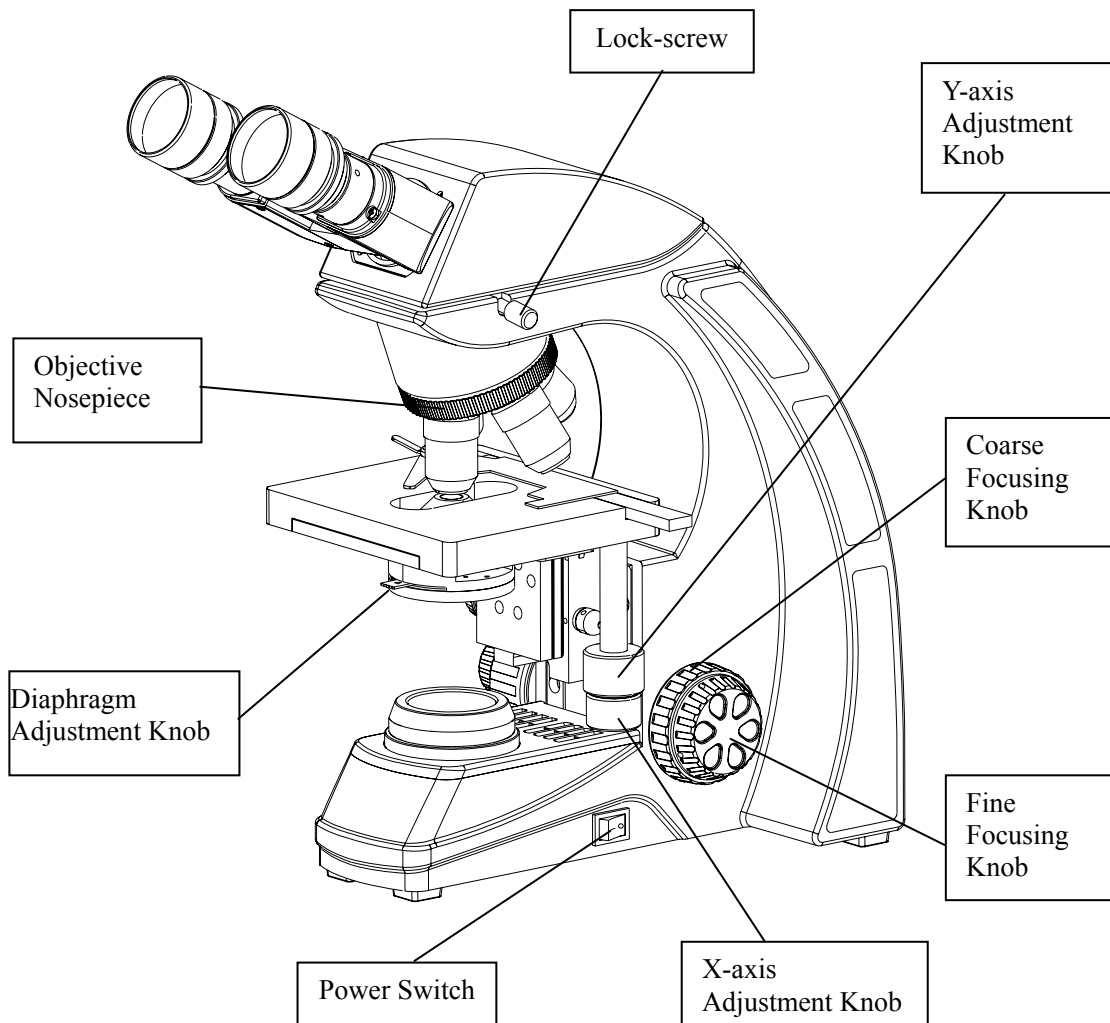

2-1 Assembling Scheme

Following is the Assembling Scheme, and the numbers denote the assembling order.

- ★ Before assembling, make sure there is no dust or dirt. Assemble carefully and do not scrap any part or touch the glass surface.

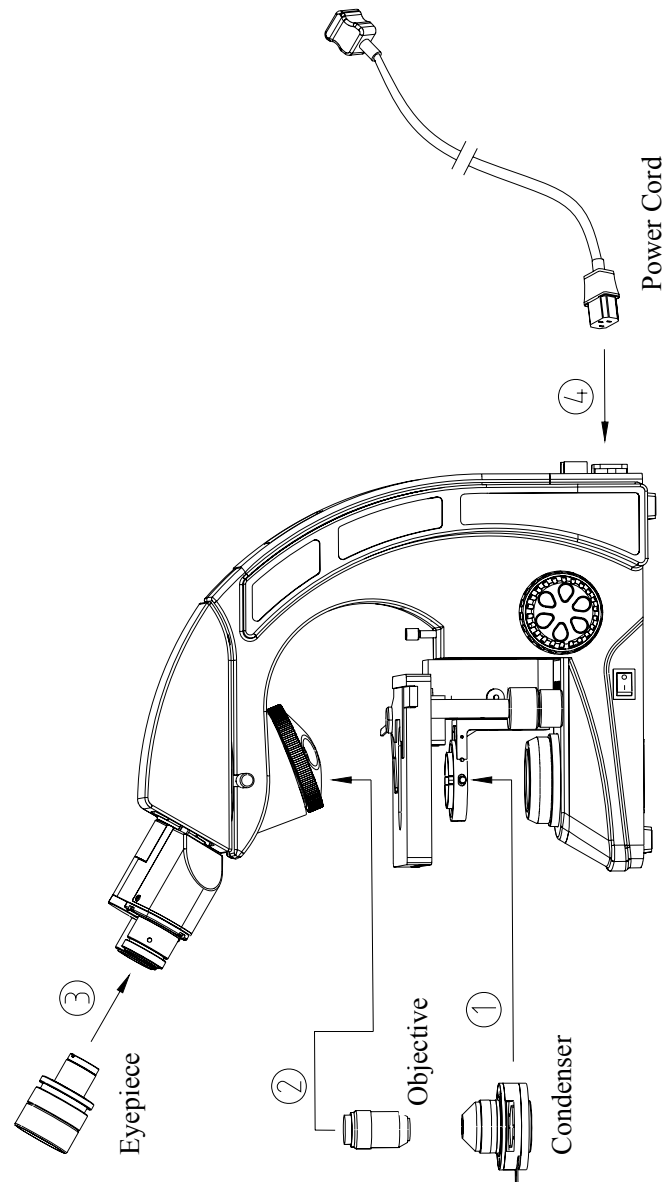

2-2 Assembling Steps

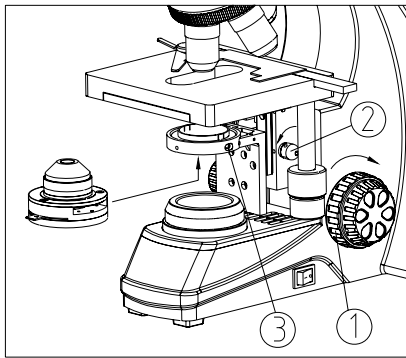

Fig. 3

2-2-1 Assemble the Condenser

1. Rotate the coarse focusing knob① to raise the stage to the highest position (see Fig. 3).
2. Rotate the condenser up-down knob② to lower the bracket of condenser to the suitable position.
3. Fully loosen the condenser lock-screw③.
4. Insert the condenser into the hole of stand according to the arrowhead, until the condenser is equal with the stand, and then rotate the condenser to make the handle frontward.
5. Tighten the lock-screw③ of condenser, then raise the condenser with the up-down knob to the highest position.

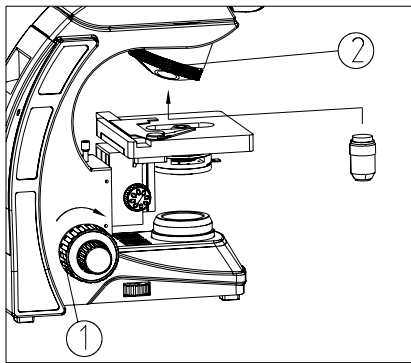

Fig. 4

2-2-2 Assemble the Objective

1. Rotate the coarse focusing knob to lower the stage to a suitable position (see Fig. 4).
 2. Install the objectives into the objective nosepiece② from the lowest magnification to the highest in a clockwise direction from the rear.
- ★ When operating, first use the low magnification objective (4X or 10X) to search for specimen and focus, and then replace with high magnification objective to observe.
 - ★ When replacing the objective, rotate the objective nosepiece until it sounds “ka-da”, to make sure the objective wanted is in the center of optical path.

图 3
图 4

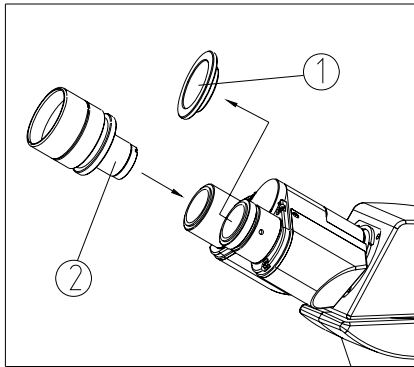

Fig. 5

2-2-3 Assemble the Eyepiece

1. Take down the cover of eyepiece tube①.
2. Insert the eyepiece② into the eyepiece tube, until touch the surface (see Fig. 5).

2-2-4 Connect the Power Cord

★ Don't use strong force when the power cord is bended or twisted, otherwise it will be damaged.

1. Make sure the power switch is at "0" (OFF) before connecting.
2. Insert the connector① of power cord into the power socket②, and make sure it connects well (see Fig. 6).
3. Insert the other connector into the socket of power supply, and make sure it connects well.

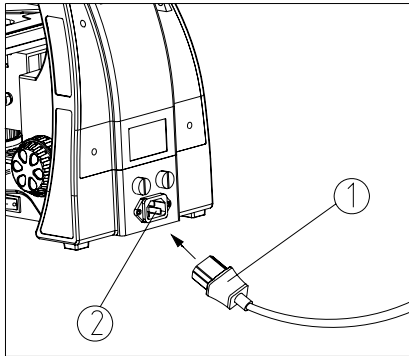

Fig. 6

★ Use the special wire supplied by our company. If it's lost or damaged, choose one with the same specifications.

★ Wide voltage range is supported as 100~240V.

★ Connect the power cord appropriately to make sure the instrument is connected to ground.

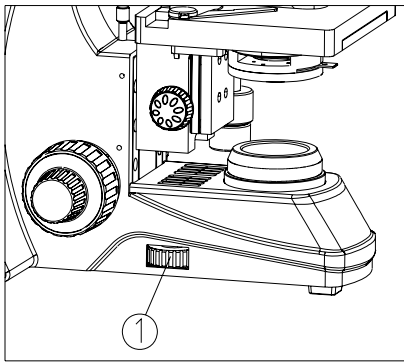

Fig. 7

3-1 Set Illumination

1. Put through the power and turn on the main power switch to “—”.
2. Adjust the light adjustment knob ① until the illumination is comfortable for observation. Rotate the light adjustment knob clockwise to raise the voltage and brightness. Rotate the light adjustment knob counterclockwise to lower the voltage and brightness (see Fig. 7).

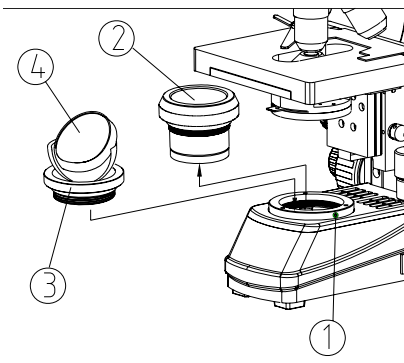

Fig. 8

Assemble the Mirror (Optional)

1. Turn off the power switch to “0”.
2. Loosen the hexagon screw ① with the spanner, to screw off the built-in Koehler illuminator condenser ② (see Fig. 8).
3. Screw on the mirror ③ according to the arrowhead pointed, and tighten the hexagon screw ① with the spanner.
4. Rotate the mirror stand ④, to fill the field with light.

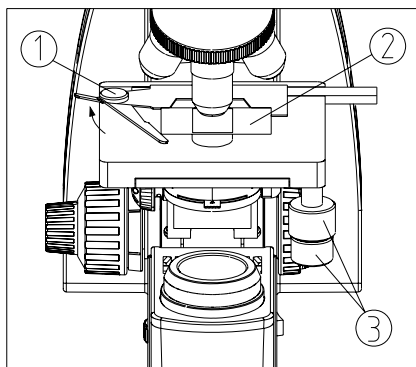

Fig.9

3-2 Place the Specimen Slide

1. Push the wrench of the specimen holder backwards.
2. Loosen the wrench ①, and clamp the slide ② by the clips while the cover glass faces up (see Fig. 9).
3. Rotate the X and Y-axis knob ③. Move the specimen to the center (alignment with the center of the objective).

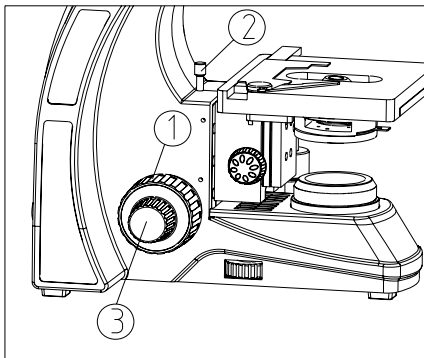

Fig. 10

3-3 Adjust the Focus

1. Move the objective 4X to the light path.
2. Observe the right eyepiece with right eye. Rotate the coarse focusing knob① until the image appears (see Fig. 10).
3. Rotate the fine focusing knob③ for clear details.

★ The position screw② can stop the objective touching the clips.

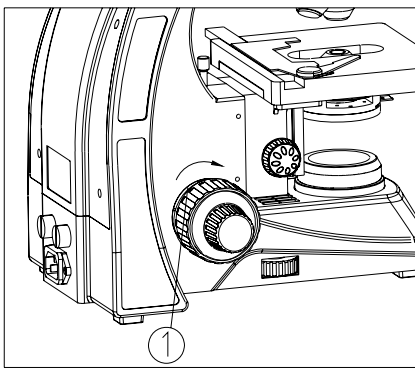

Fig. 11

3-4 Adjust the Focusing Tension

If the handle is very heavy when focusing or the specimen leaves the focus plane after focusing or the stage declines itself, please adjust the tension adjustment ring① (see Fig. 11).

To tighten the focusing arm, rotate the tension adjustment ring① according to the arrowhead pointed; to loosen it in the reverse direction.

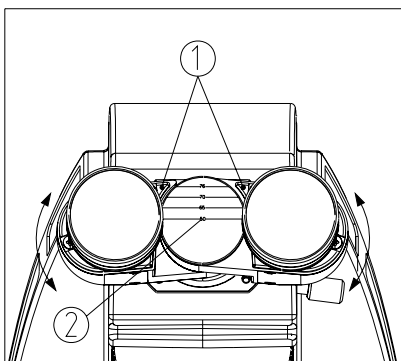

Fig12

3-5 Adjust the Interpupillary Distance

When observe with two eyes, hold the base of the prism and rotate them around the axis until there is only one field of view.

“。”① on the eyepiece base points to the scale② of interocular indication, which means the value of interocular distance (see Fig. 12).

Range: 50~76mm.

★Remember your interpupillary distance for further operation.

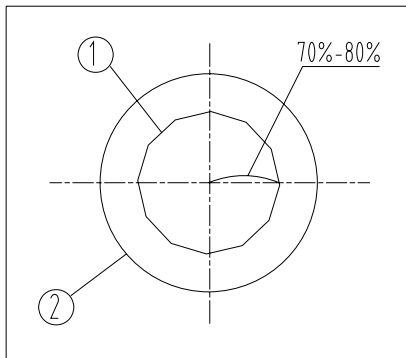

Fig. 13

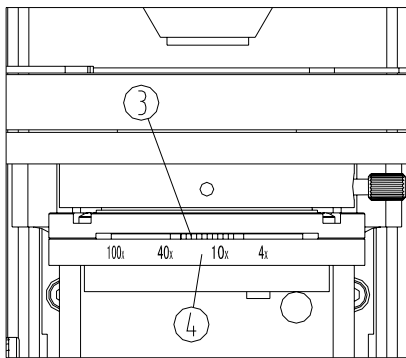

Fig. 14

3-6 Adjust the Field Diaphragm (Iris Diaphragm Koehler Illuminator Condenser Optional)

By limiting the diameter of the beam entering the condenser, the field diaphragm can prevent other light and strengthen the image contrast. When the image is just on the edge of the field of view, the objective can show the best performance and obtain the clearest image.

3-7 Adjust the Aperture Diaphragm

1. The aperture diaphragm decides the numerical aperture of the illumination. Only when the N.A. of illumination is matching with the N.A. of the objective, it can obtain better resolution and contrast, and also increase the depth of field.

2. As the contrast is usually low, rotate the handle ③ to make the arrowhead pointed to the related magnification position on condenser base ④, namely, to adjust the N.A. of illumination to 70%-80% of the N.A. of objective. The eyepiece can be taken off when it's necessary to observe from the tube.

Adjust the ring ③ until see the figure as shown in Fig. 13, to adjust the proportion (see Fig. 13&14, ① is the image of aperture diaphragm, ② is the edge of objective).

3-8 Use the Oil Objective (100X)

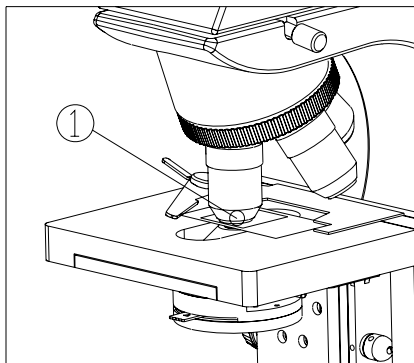

Fig. 15

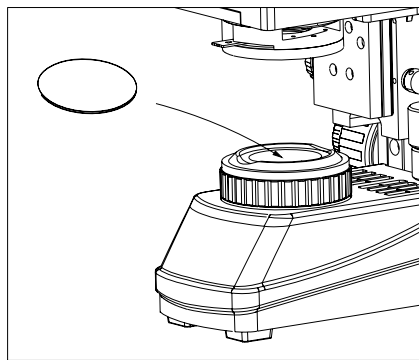

Fig. 16

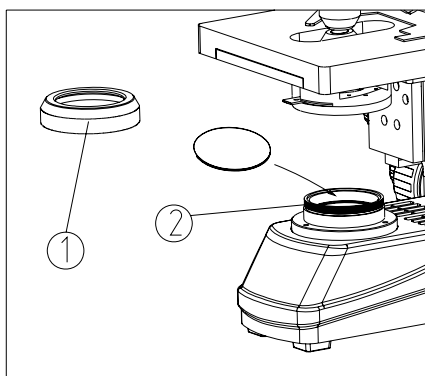

Fig. 17

1. Use objective 4X to focus the specimen.
2. Place a drop of oil① on the specimen (see Fig. 15).
3. Rotate the nosepiece counterclockwise and rotate the oil objective (100X) to the light path. Then use the fine focusing knob to focus.

★ Make sure there is no air bubble in the oil for fear affect the image..

A. Move the eyepiece to examine the air bubble. Open the aperture diaphragm and field diaphragm fully and observe the edge of the objective from the tube (It seems round and light).

B. Rotate nosepiece slightly and swing the oil objective for some times to remove the air bubble.

4. After using, wipe the front lens with a tissue moistened with a small amount of 3:7 mixture of alcohol and ether or with dimethylbenzene. Wipe oil on the specimen.

★ Don't put another objective to the light path before the oil is wiped to avoid wetting the dry objective.

★ Too much dimethylbenzene would dissolve the lens's stickiness.

3-9 Use the Filter

Filter can make the background more suitable and increase the contrast.

Iris diaphragm Koehler Illuminator Condenser (Optional)

Put the filter into the groove of condenser (see Fig. 16).

Built-in Koehler Illuminator Condenser

Screw off the condenser cover① from condenser base②, and put the filter into the groove of condenser base②, and then screw on the condenser cover① (see Fig. 17).

★ There are four kinds of filter: blue, green, yellow and white.

★ Place the filter's rough side downward.

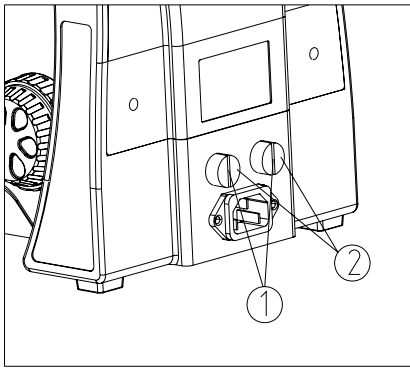

Fig. 18

3-10 Replace the Fuse

Turn the main switch to “0” (OFF) before replacing the fuse. Pull out the power cord. Then screw off the fuse group ① from the fuse base ② with a “-” type screwdriver. Install a new fuse and screw it on the fuse base (see Fig. 18).

★ **Specification of the fuse: 250V, 3.15A.**

4. Technical Specifications

MT-40 Series

4-1 MT-40 Series Biological Microscope Technical Parameters

Optical system	UIS (universal infinity-corrected optical system)
Head	Binocular head of Gemel type, 30° inclined
Eyepiece	PL10X18T diopter adjustable eyepiece, 18mm line field of view
Nosepiece	Reversed quadruple nosepiece
Objective	Infinity Plan achromatic objective (4X, 10X, 40X, 100X)
Focusing system	Coaxial coarse& fine focusing system, with limit-stopper& tension adjustable. Travel rang: 25mm. Fine focusing precision: 0.002mm
Stage	Rectangle built in low position coaxial mechanical stage, single slide clip, area 140x132mm, moving range 76x50mm
Condenser	Built-in Koehler illuminator systems, Pre-centered. Iris diaphragm Koehler illuminator condenser and mirror optional.
Illuminator	100~240V wide voltage., output single 3W LED light, continuous adjustment of brightness.
Operation Environment	<ul style="list-style-type: none"> ● Use indoor ● Altitude: max. 2000m ● Environment temperature: 5°C-40°C (41°F-109°F) ● Max. relative humidity: 80% at 31°C (88°F) , and then declined linearly. 70% at 34°C (93°F) , 60% at 37°C (99°F) , 50% at 40°C (104°F) . ● Degree of pollution: 2 (refer to IEC664)

4-2 Parameters of objective

Type	Magnification	Numerical aperture (N.A.)	Conjugate distance(mm)	Parfocal distance(mm)	Thickness of the cover slip	Magnification market (color ring)
Infinity Plan achromatic objective	4X	0.10	∞	45	0.17	Red
	10X	0.25	∞	45	0.17	Yellow
	40X(S)	0.65	∞	45	0.17	Light Blue
	100X(S)oil	1.25	∞	45	0.17	White

As the performance of microscope can't play fully due to unfamiliar operations, the table below can provide some solutions.

Problem	Cause	Solution
1. Optical Part		
(1) The LED light is bright, but it's dark in the field of view.	Field diaphragm is not large enough.	Enlarge the field diaphragm.
	Condenser is too low.	Adjust the condenser.
(2) The side of the field of view is dark or not even.	The nosepiece is not in the right position.	Turn the nosepiece into the right position.
	Stain or dust has accumulated on the condenser, objective, eyepieces, and base lens.	Clean the lens.
(3) Stain or dust is observed in the field of view.	Stains have accumulated on the specimen.	Clean the specimen.
	Stains have accumulated on the lens.	Clean the lens.
(4) Unclear image	No cover glass on the specimen slide.	Add the cover glass.
	The cover glass is not standard.	Use a standard cover glass with thickness 0.17mm.
	The cover glass faces down.	Put the cover glass to face up.
	The immersion oil has accumulated on the dry objective.	Clean thoroughly.
	The immersion oil is not used for oil objective 100XR.	Use immersion oil.
	Air bubble in the immersion.	Get rid of the air bubble.
	Use wrong immersion oil.	Use a correct one.
	The aperture is not opened correctly.	Adjust the iris diaphragm.
	Stain or dust has accumulated on the lens in the inlet of the head.	Clean the lens.
	The condenser is not in the right position.	Adjust the condenser.
(5) One side of the field of view is dark or the image moves while focusing.	The specimen slide is not fixed.	Fix with clips.
	The nosepiece is not in the right position.	Turn the nosepiece into the right position.
	Condenser centered incorrectly.	Center the condenser.

Problem	Cause	Solution
(6) The eyes feel tired easily. The right field of view doesn't superpose with the left.	Interpupillary distance is wrong.	Adjust the interpupillary distance.
	The eyepieces for the right are different from the left.	Use the same eyepieces.
2. Mechanical Part		
(1) Can not get the objective focused.	The cover glass faces down.	Put the cover glass to face up.
	The cover glass is not standard.	Use a standard cover glass with thickness 0.17mm.
(2) The objective touches the cover glass while turning the nosepiece.	The cover glass faces down.	Put the cover glass to face up.
	The cover glass is not standard.	Use a standard cover glass with thickness 0.17mm.
(3) Coarse focusing knob is too tight.	Tension knob is too tight.	Loosen a little.
(4) Stage declines itself.	Tension knob is too loose.	Tighten a little.
(5) Coarse focusing knob can't rise.	The limit stop knob is locked.	Loosen the knob.
(6) Coarse focusing knob can't decline.	The base of the condenser is too low.	Raise the base.
(7) Can not move the slide smoothly.	The slide is not fixed correctly.	Adjust it correctly.
	The movable specimen holder is not fixed properly.	Adjust it correctly.
(8) The image moves obviously when touching the stage.	The stage is fastened incorrectly.	Fasten the stage correctly.
3. Electrical Part		
(1) The LED light does not work.	No power supply.	Check the connection of the power cable.
	The LED light is not inserted correctly.	Insert it correctly.
	The LED lights burnt out.	Replace it.
(2) The LED light burnt out usually.	Use a wrong LED lights.	Replace with a correct one.
(3) The field of view is not bright enough.	Use a wrong LED lights.	Replace with a correct one.
	The use of light adjustment knob is wrong.	Adjust correctly.